

REMOVING THE BLIND

CLASSIC ROMAN BLIND

Press the release tab at front of all brackets. Tilt headrail's back end and release from front.

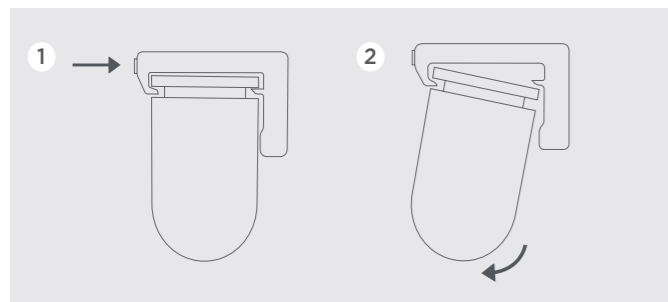

CASSETTE ROMAN BLIND

Press the back tab of all brackets. Tilt cassette's back end and release from front.

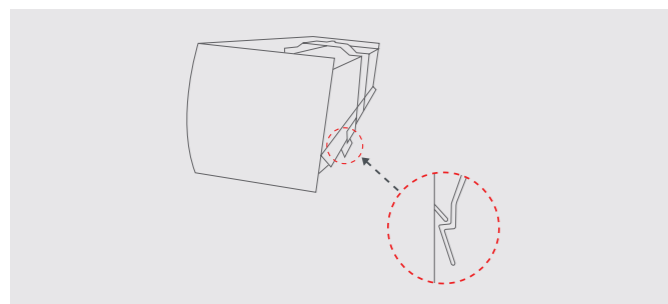

MAINTANANCE

The product is maintenance free however we recommend that regular visual checks are completed to ensure that no components have been damaged, which could result in operating difficulties and/or cause a safety risk. If any maintenance is required we recommend that the work is carried out immediately, by a reputable blind company.

CLEANING INSTRUCTIONS:

Use a dry lint free cloth to wipe over the fabric of the blind.

CHILD SAFETY

CORD SAFETY

The cords on the back are connected to breakaway clips which disconnect when weight is put on the cords.

To attach it, push the connector to the clip until it clicks.

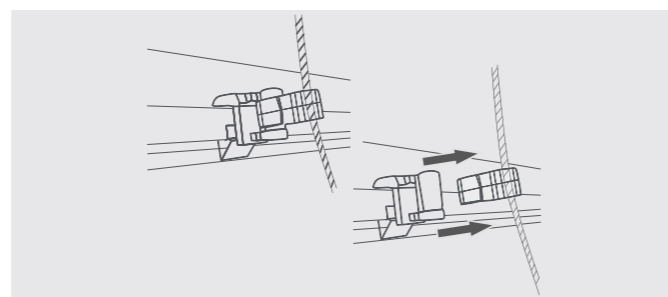

BREAKAWAY CLUTCH

Blind can be supplied with a breakaway safety clutch so that when a horizontal force is applied to the chain, the wheel in the clutch safely breaks away eliminating any hazardous loops. If the safety device is activated, untangle and untwist the chain and reattach.

HOW TO REATTACH:

Place the chain around the wheel. Matching up the wheel to the adjacent sides of the clutch, push the wheel back into place until you hear the click.

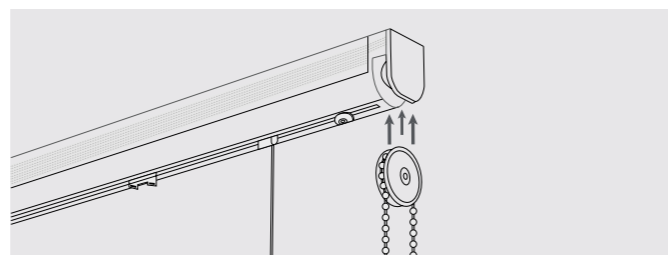

WARNING

Young children can be strangled by loops in pull cords, chains, tapes and inner cords that operate the product.

To avoid strangulation and entanglement, keep cords out of the reach of young children. Cords may become wrapped around a child's neck. Move beds, cots and furniture away from window covering cords.

Do not tie cords together. Make sure cords do not twist and create a loop.

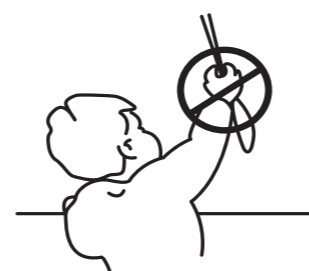

ROMAN BLINDS

YOU SHOULD HAVE

- Roman blind (Classic or Cassette)

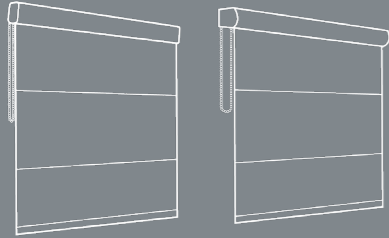

- Fixing brackets
- Screws

YOU WILL NEED

- Drill
- Screwdriver
- Tape measure
- Pencil
- Spirit level

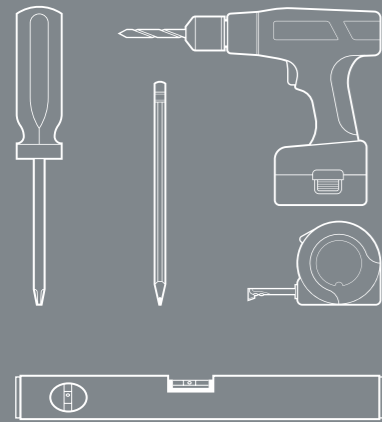

WARNING:
PLEASE TAKE CARE
WHEN UNPACKING
YOUR BLIND, DO NOT
USE A KNIFE OR ANY
SHARP OBJECTS.

THE INSTALLATION OF THIS PRODUCT SHOULD BE CONDUCTED BY SOMEONE COMPETENT IN DIY. PLEASE READ THE INSTRUCTIONS BEFORE OPERATING THIS PRODUCT.

STEP 1 - FITTING THE BLIND

Deciding where to mount the brackets:

Before you start fitting your blind make sure the screws are suitable for the surface you are fitting into. Some surfaces will require wall plugs and different screws to the ones we provide.

Ensure that brackets are positioned a suitable distance away from any window/door handles or any other obstructions to allow the blind to operate smoothly.

CLASSIC HEADRAIL

1. MEASURE

The brackets need to be positioned 50mm in from each side of the blind. Using your tape measure, mark these points with a pencil. Evenly space additional brackets between the two end brackets.



2. FIX BRACKETS

Choose whether you need to fit your brackets via top fix or face fix. Hold the brackets up to the pencil marks made in previous step. Mark the relevant hole with a pencil. With a spirit level, check the brackets are level.

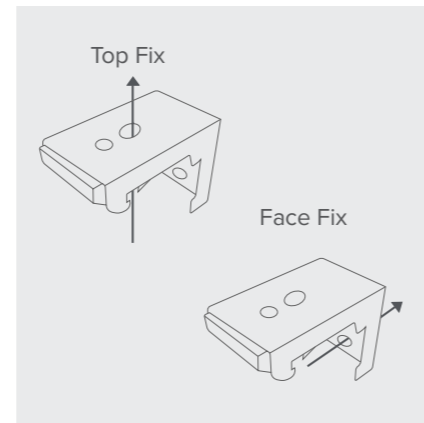

3. HOOK, TILT, CLICK

When the brackets are fitted, hook the ridge on the top of the headrail into the front of the brackets then push and tilt the headrail back until it clicks into the back part of the bracket.

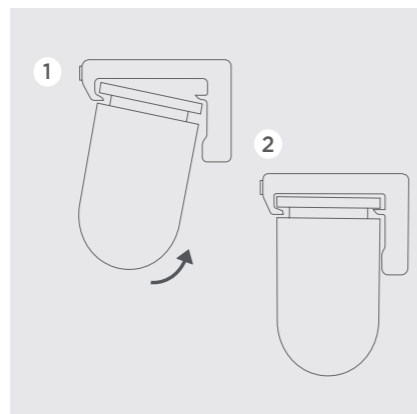

CASSETTE HEADRAIL

1. MEASURE

The brackets need to be positioned 50mm in from each side of the blind. Using your tape measure, mark these points with a pencil. Evenly space additional brackets between the two end brackets.



2. FIX BRACKETS

Choose whether you need to fit your brackets via top fix or face fix. Hold the brackets up to the pencil marks made in previous step.

Mark the relevant hole with a pencil. Drill holes and use suitable screws to fix the brackets. With a spirit level, check the brackets are level.

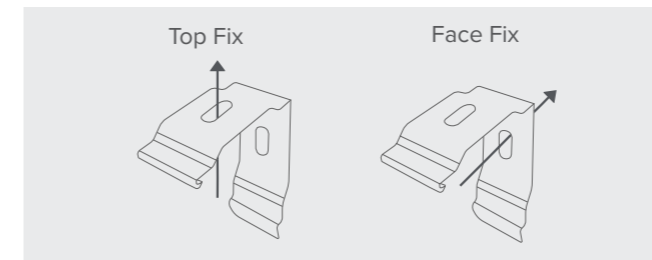

3. HOOK, TILT, CLICK

When the brackets are fitted, hook the ridge on the top of the cassette into the front of the brackets then push and tilt the cassette back until it clicks into the back part of the bracket.

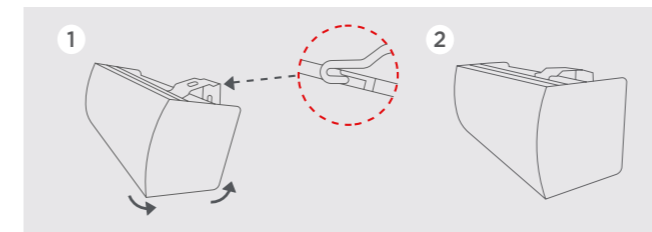

4. REMOVE TRANSIT CLIP

Remove transit clip and discard.

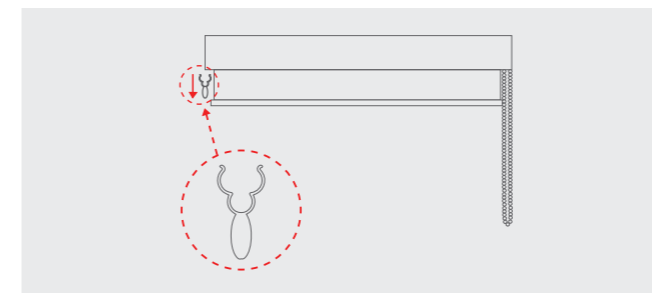

STEP 2 - FITTING CHILD SAFETY P-CLIP

CHILDREN CAN BE STRANGLERED IF A SAFETY DEVICE IS NOT INSTALLED. ALWAYS USE A SAFETY DEVICE TO KEEP CORDS AND CHAINS OUT REACH OF CHILDREN.

If your blind is motorised or supplied with breakaway connector this step can be skipped.

The child safety device (P-clip) must be installed at maximum distance possible from the control mechanism to prevent the looped cord/chain from becoming slack.

1. Control chain must be inside the P-clip.
2. Ensure the chain is taut and that the P-clip is at the bottom of the loop. Make sure the chain can manoeuvre properly.
3. Screw the P-clip to a wall ensuring that the chain remains taut.

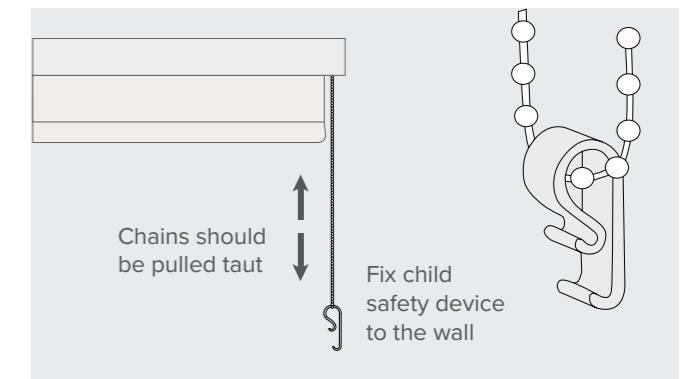

STEP 3 - OPERATING THE BLIND

Pull the chain to raise and lower the blind. Do not continue pulling when the blind is fully retracted as you will damage it.

