



**somfy** Building  
happiness

BATTERY POWERED ROLLER MOTOR MANUAL  
ROLL UP 24, ROLL UP 28, SONESSE 28 AND SONESSE ULTRA 30  
FIT020 - V1



# TABLE OF CONTENTS

<b>FITTING INSTRUCTIONS</b>	4-5
BRACKETS INCLUDED/ TOOLS REQUIRED	4
RECESS	4
OUTSIDE RECESS	4
INSIDE RECESS	4
FIXING POSITION	4
TOP FIXING	4
FACE FIXING	5
MOUNTING BLIND ONTO BRACKETS	5
<b>OPERATING YOUR SOMFY REMOTE</b>	6
<b>OPERATING INSTRUCTIONS</b>	7
WAKING THE MOTOR UP	7
OPERATING THE BLIND	7
SINGLE CHANNEL REMOTE	7
MULTI-CHANNEL REMOTE	7
<b>PROGRAMMING INSTRUCTIONS</b>	9-14
ACTIVATING TEMPORARY SLEEP MODE	9
DEACTIVATING SLEEP MODE	9
CHECKING THE REMOTE IS PAIRED WITH THE MOTOR	9
PAIRING A REMOTE	10
SINGLE CHANNEL REMOTE	10
MULTI-CHANNEL REMOTE	10
PAIRING A SECOND REMOTE	10
SINGLE & MULTI-CHANNEL REMOTE	10
ADDING A CHANNEL	11
MULTI-CHANNEL REMOTE	11
DELETING A CHANNEL	11
MULTI-CHANNEL REMOTE	11
ADJUSTING THE MOTOR ROTATION DIRECTION	12
ADJUSTING UPPER LIMIT	12
ADJUSTING LOWER LIMIT	13
SETTING INTERMEDIATE LIMIT	13
SPEED ADJUSTMENT MODE	13
INCREASING THE MOTOR SPEED	14
DECREASING THE MOTOR SPEED	14
CONFIRMING NEW SETTINGS	14
RESTORE TO FACTORY SETTINGS	14
CORRECTING FABRIC RUN-OFF	14

# FITTING INSTRUCTIONS

## BRACKETS INCLUDED

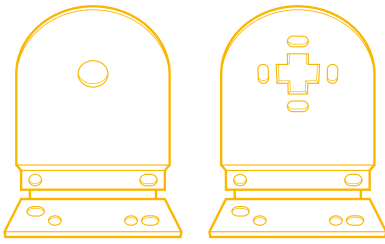

## TOOLS REQUIRED

- Screwdriver
- Pencil
- Power-Drill
- Tape Measure

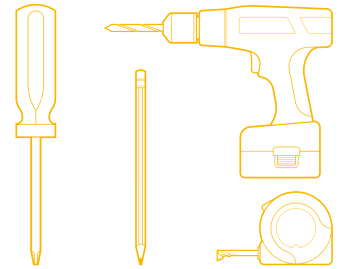

**Note:** In order to protect your blind during transit, the motor will be placed in sleep mode, prior to installation you will need to wake the motor up. Refer to operating instructions on waking the motor up.

Note: The installation of this product should be conducted by someone competent in DIY.

## RECESS

### OUTSIDE RECESS

1. If the blind is to be fitted outside the window ensure that measurement C is the same. Follow instructions for FACE FIXING. To calculate C  $(A-B)/2$ .

### INSIDE RECESS

1. TOP FIX to the lintel. FACE FIX bracket to the window frame.

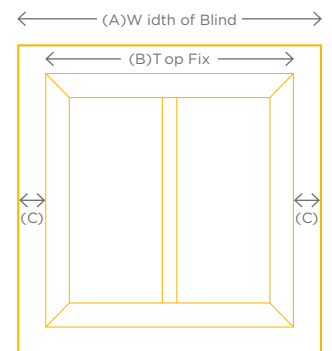

## FIXING POSITION

### TOP FIXING

1. If the blind is to be fitted outside the window ensure that measurement C is the same. Follow instructions for FACE FIXING. To calculate C  $(A-B)/2$ .
2. Hold each bracket into place and mark the hole positions.
3. Fit each bracket using suitable screws.

Note: Please ensure fixings are suitable for the wall/surface to which you are mounting the brackets.

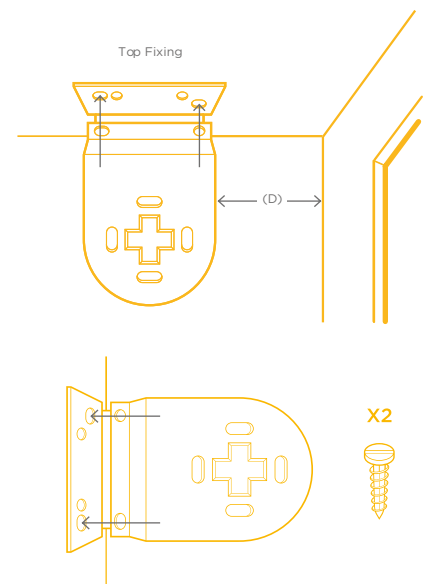

# FITTING INSTRUCTIONS

## MOUNTING BLIND ONTO BRACKETS

1. Holding the fully-wound blind, insert the idle pin end into the bracket as shown.

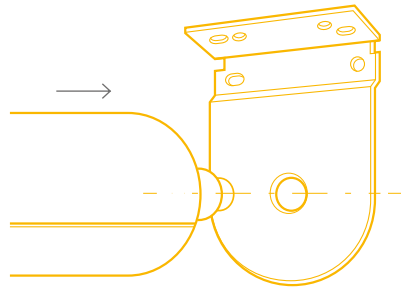

2. With the Idle pin end in place. Insert the control end into the opposite bracket by depressing the pin end then pull down vertically until the control end clicks into position.

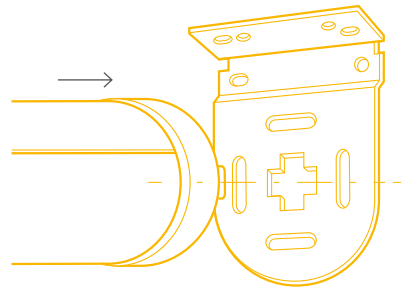

# OPERATING YOUR SOMFY REMOTE

SITUO 1 RTS

SITUO 5 RTS

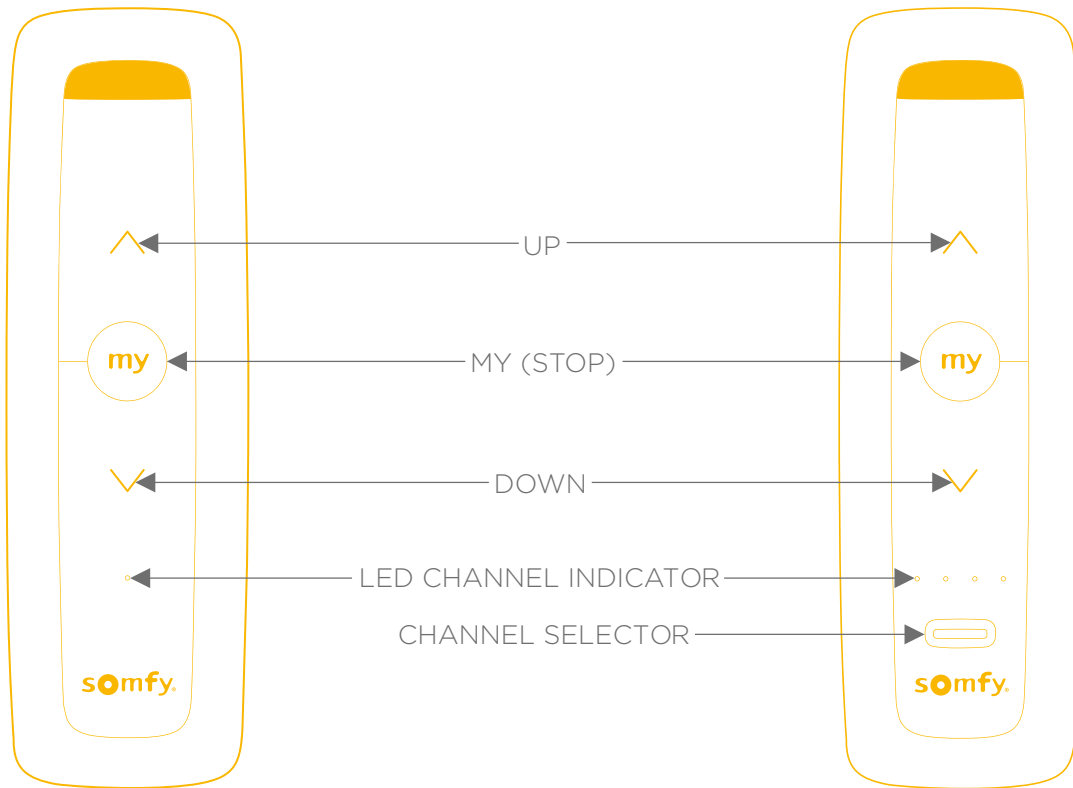

BACK OF REMOTE

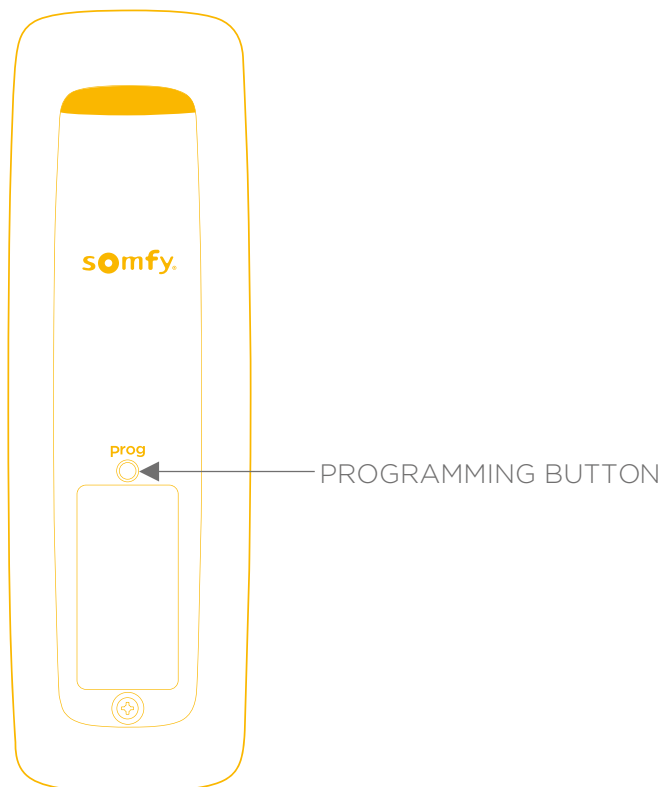

# OPERATING INSTRUCTIONS

## WAKING THE MOTOR UP

Press and hold the programming button on the motor head for 1 second, the blind will jog once.

*Note: The motor programming button will look different depending on the model you have opted for.*

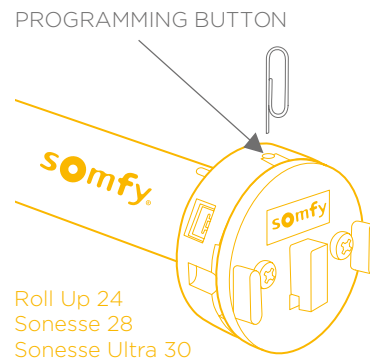

## OPERATING THE BLIND

*Note: The remote and blind should arrive paired and the lower and upper limits on the blind will be pre-set. You can operate the blind immediately, or if you wish to adjust the limits please follow the adjusting limits instructions in the programming section.*

### SINGLE CHANNEL REMOTE

1. Briefly press the **UP** button to move to the upper limit
2. Briefly press the **DOWN** button to move to the lower limit.

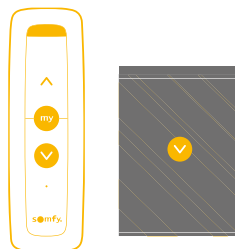
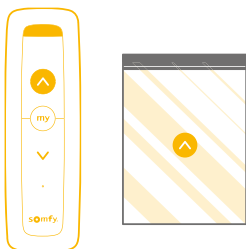

### MULTI-CHANNEL REMOTE

1. Using the **CHANNEL SELECTOR**, select the desired channel. (Channel indicator will briefly be lit)
2. Briefly press the **UP** button to move to the upper limit.
3. Briefly press the **DOWN** button to move to the lower limit.

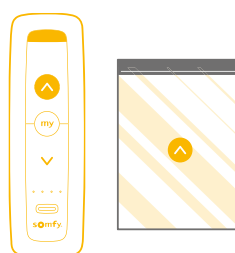
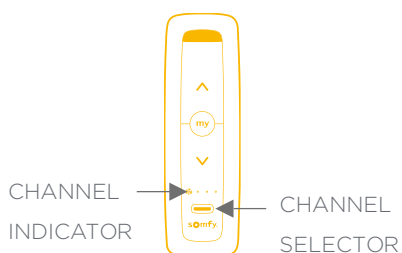





# PROGRAMMING INSTRUCTIONS

**Note: To programme blinds individually, wake the individual motor up and programme one motor at a time.**

## ACTIVATING TEMPORARY SLEEP MODE

1. Press and hold the programming button on the motor head and the blind will jog once. Briefly press the programming button and the motor will jog twice. The LED will flash orange while the motor is in temporary sleep mode.

*Note: Temporary sleep mode lasts 15 minutes.*

## DEACTIVATING SLEEP MODE

1. Press and hold the programming button on the motor head for 1 second, the blind will jog once.

## CHECKING THE REMOTE IS PAIRED WITH THE MOTOR

1. Press the **UP** or **DOWN** button on the remote. If the blind moves the remote is paired, if the blind does not move, follow “pairing a remote” instruction.

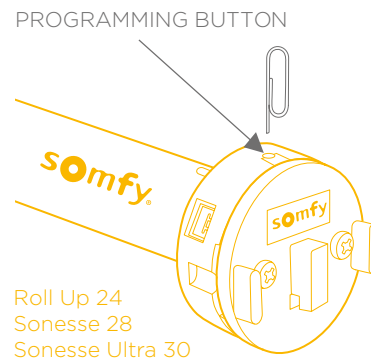

# PROGRAMMING INSTRUCTIONS

## PAIRING A REMOTE

### SINGLE CHANNEL REMOTE

1. Once the motor has been woke, on the remote press and hold the **UP** and **DOWN** buttons simultaneously until the blind jogs.



### MULTI-CHANNEL REMOTE

*Note: When pairing a Multi-Channel remote, ensure you have selected the correct channel in which you wish to operate the blind on.*

1. Using the **CHANNEL SELECTOR**, select the desired channel (channel indicator will briefly be lit).

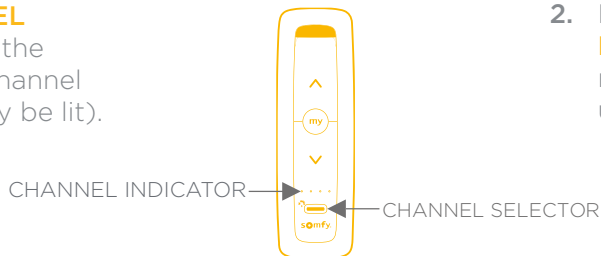

2. Press and hold the **UP** and **DOWN** buttons on the remote simultaneously until the blind jogs.



## PAIRING A SECOND REMOTE

### SINGLE & MULTI-CHANNEL REMOTE

1. Using a paperclip or pen, press and hold the **PROGRAM** button on the original remote until the blind jogs once.

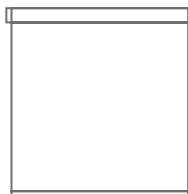

2. Using a paperclip or pen, press the **PROGRAM** button on the new remote until the blind jogs once. The new remote is now added to the memory and can be used to operate the blind.

ORIGINAL REMOTE

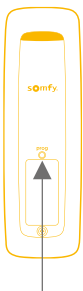

Press for 1 sec

ORIGINAL REMOTE



NEW REMOTE



NEW REMOTE

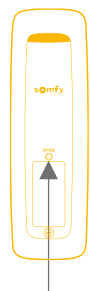

Press for 3 secs

# PROGRAMMING INSTRUCTIONS

## ADDING A CHANNEL

### MULTI-CHANNEL REMOTE

1. Select the desired channel you wish to duplicate by momentarily pressing the **CHANNEL SELECTOR** button on the multichannel remote.
2. Using a paperclip or pen, press and hold the **PROGRAM** button on the remote until the blind jogs once.
3. Ensuring you are on the new channel press the **PROGRAM** button on the remote until the blind jogs once. Additional (new) channel is now added to the motor memory and can be used to operate the blind.

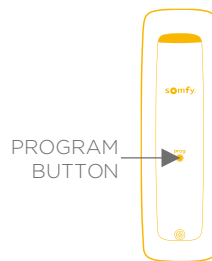
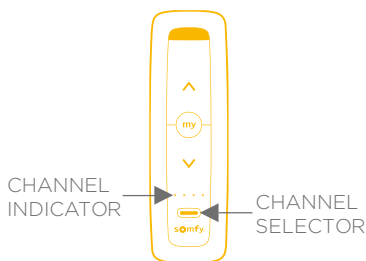

## DELETING A CHANNEL

### MULTI-CHANNEL REMOTE

1. Using a paperclip or pen, press and hold the **PROGRAM** button on the remote until the blind jogs once.
2. On the remote select the desired channel to be deleted.
3. Press the **PROGRAM** button on the remote until the blind jogs once. Channel is now deleted from the motor memory and will not operate the blind.

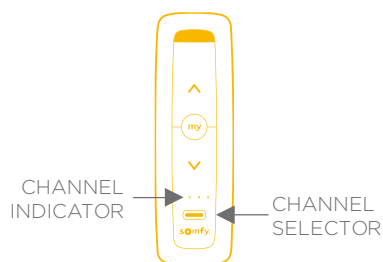

# LIFT PROGRAMMING INSTRUCTIONS

*Note: Should your blind run in the opposite direction to the remote instruction follow the below steps to correct.*

## ADJUSTING THE MOTOR ROTATION DIRECTION

1. Press the **UP** or **DOWN** button on the remote to move the blind away from the end
2. Press and hold the **UP** and **DOWN** buttons simultaneously until the blind jogs.
3. Press and hold the **MY** (Stop) button until the blind jogs, the rotation direction is now reversed
4. Press the **UP** button to check the new rotation direction.



---

## ADJUSTING UPPER LIMIT

**NOTE: BLIND LIMITS WILL BE PRE-SET ON ARRIVAL**

1. Briefly press the **UP** button. The blind will move to pre-set upper limit.
2. Press and hold the **UP** and **DOWN** buttons until the blind jogs.
3. Press and hold the **UP** or **DOWN** button to move the blind to the new desired position.
4. To confirm the new position press and hold the **MY** (Stop) button until the blind jogs. The new upper limit is now added to the memory



# PROGRAMMING INSTRUCTIONS

## ADJUSTING LOWER LIMIT

1. Briefly press the **DOWN** button. Blind will move to pre-set lower limit
2. Press and hold the **UP** and **DOWN** button until the blind jogs.
3. Press and hold the **UP** or **DOWN** button to move the blind to the desired lower position.
4. To confirm the new position press and hold the **MY** (Stop) button until the blind jogs. The new lower limit is now added to the memory.



## SETTING INTERMEDIATE LIMIT (FAVOURITE POSITION)

*Note: The intermediate limit is optional and has not been pre-set.*

1. Move the blind to the desired intermediate limit using the **UP** or **DOWN** buttons.
2. Briefly press the **MY** (Stop) button to stop at the desired intermediate limit.
3. Press and hold the **MY** (Stop) button until the blind jogs, the intermediate limit is now memorised.



## SPEED ADJUSTMENT MODE

*Note: To increase or decrease the motor speed, you must first enter speed adjustment mode.*

1. Press the **UP** or **DOWN** button on the remote to move the blind away from the end limits.
2. Press and hold the **UP**, **MY** and **DOWN** buttons simultaneously until the blind jogs once.
3. The blind will jog in 10 second cycles until it enters into speed adjustment mode.

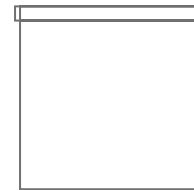

# PROGRAMMING INSTRUCTIONS

## INCREASING THE MOTOR SPEED

Press and hold the **UP** button until the blind jogs, repeat as needed. The maximum setting has been reached when the blind briefly moves 3 times in one direction and three times in the opposite direction.



## DECREASING THE MOTOR SPEED

Press and hold the **DOWN** button until the blind jogs, repeat as needed. The minimum setting has been reached when the blind briefly moves 3 times in one direction and three times in the opposite direction.



## CONFIRMING NEW SPEED SETTINGS

Press and hold the **MY** button until the blind briefly jogs.



## RESTORE TO FACTORY SETTINGS

To delete all previous settings: Using a paperclip or pen, press and hold the **PROGRAM** button on the motor head until the blind jogs 3 times. All remotes and limits will be erased from the motor memory. Motor is now reset to factory mode.

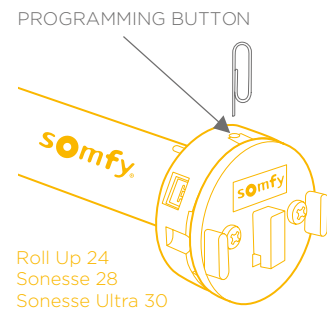

## CORRECTING FABRIC RUN-OFF

Diagram 1 shows the fabric running off from the right-hand side of the blind. To correct the run-off, move the blind to the furthest lower position, place a 25mm piece of sticky tape onto the tube (Diagram 2) at the opposite end of the blind to the run-off. Move the blind to the furthest upper position. Repeat until the fabric is no longer running-off.

DIAGRAM 1

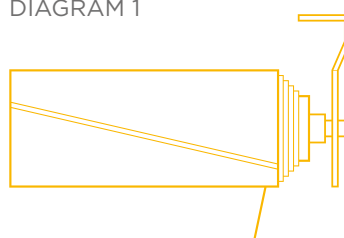
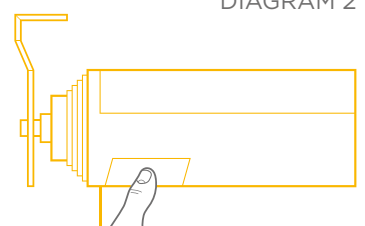

DIAGRAM 2





**somfy**® **Building  
happiness**

**CE** As the manufacturer, Somfy ACTIVITIES SA, F-74300 CLAUSES hereby declares that the drive covered by these instructions, when used as intended according to these instructions, is in compliance with the essential requirements of the applicable European directives, in particular the Machinery Directive 2006/42/EC and EMC Directive 2014/30/EU.

The full text of the EU declaration of conformity is available at [www.somfy.com/ce](http://www.somfy.com/ce). Antoine Crézé, Approval manager, acting on behalf of Activity director, Cluses, 02/2019.



Please separate storage cells and batteries from other types of waste and recycle them via your local collection facility.



We care about our environment. Do not dispose of the appliance with usual household waste. Give it to an approved collection point for recycling.

