

Bloc Skylight Blind Solar Motorised



Motorised
option
available

Compatible with all major brands. Harnessing the energy from the sun via a discreet solar panel. The solar panel is designed to charge the battery during daylight hours throughout the lifetime of the blinds. Even in the event of no sunshine, the battery will last for 300 operations.

Installation of the blind couldn't be simpler. Our 6 screw system means installation is easy and mess free.



Aluminium Colour Options



Anodised Silver
Natural Finish

Features

Bloc Blinds incorporate a number of specially developed features that enhance the premium quality of our blinds;



Belts

The tracks in the siderail connect them to the handle.

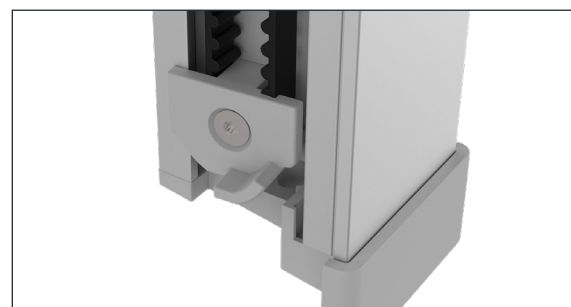

The Belt Tensioner

The belt tensioner means the tension has been pre-set at point of manufacturing leading to easier installation.

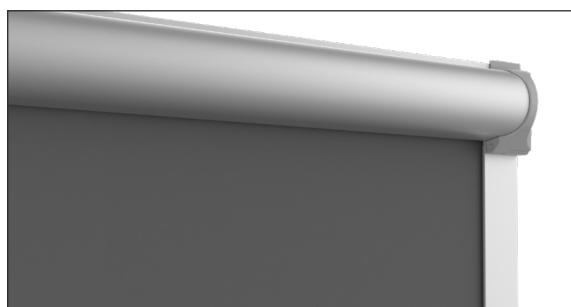

Fabric

The fabric is completely enclosed, reducing fading and significantly extending the life of the fabric.

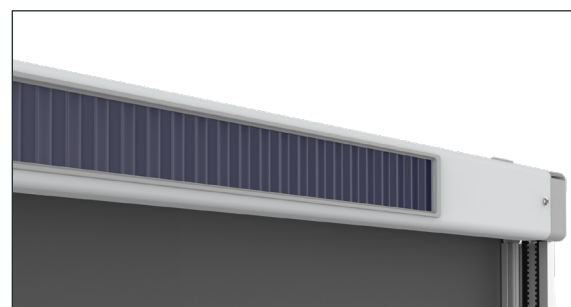

Solar Panel

The discreet solar panel harnesses and stores the sun's energy using it to operate the blind.

Product Specification

Roller Tube	Aluminium
Cassette Colour	Anodised Silver
Control	Motorised (12v)
Fabric Position	Standard Roll
Sizes	All manufacturing Codes
Suitable for	Velux® Roof Windows, Dakstra®, Fakro®, Roof Lite®, Roto® (exc 300 series)

Product Dimensions

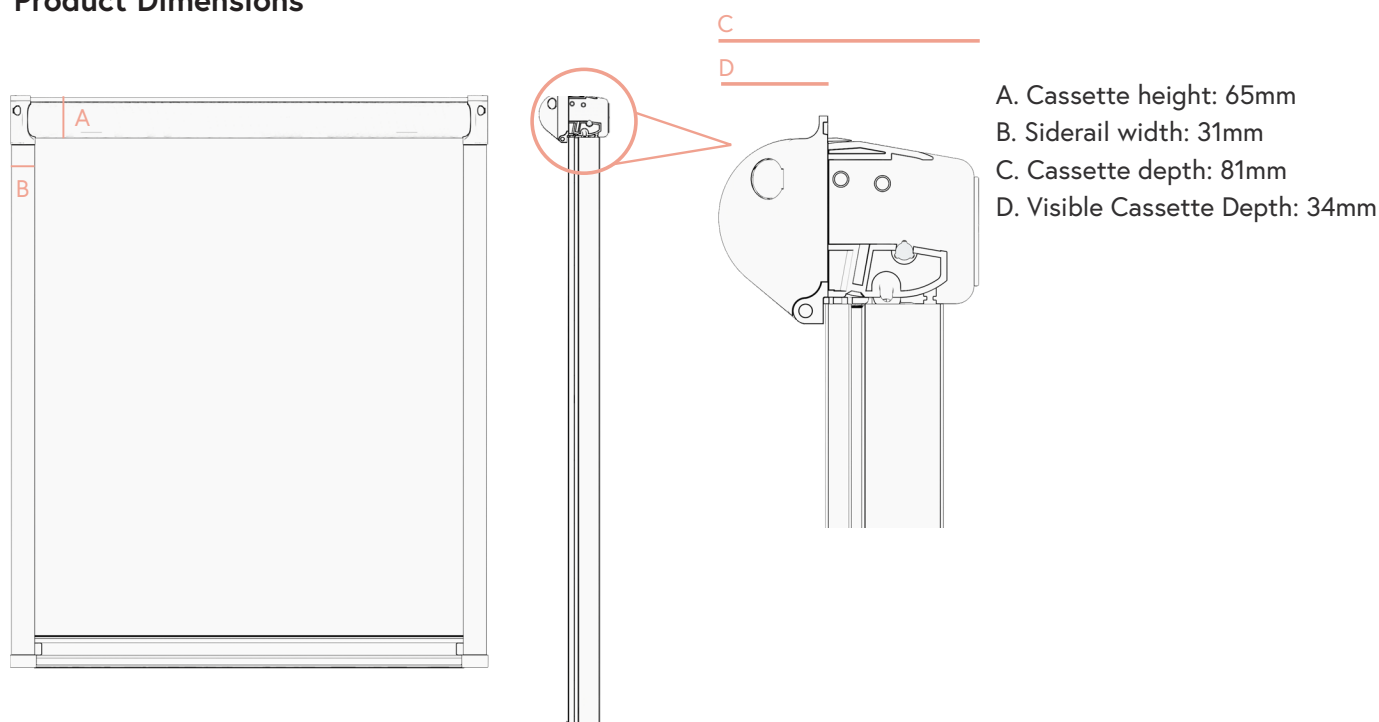

Battery Life

The solar panel is designed to charge the battery during daylight hours throughout the lifetime of the blind, in the event of no sunlight the battery will last for 300 operations.

Operation

The blind is operated with motorised or Smart motorised system. The blind is supplied with a multi-channel remote capable of operating up to 20 blinds in each of its 15 channels.

Care

To keep the blind looking it's best through time the customer must ensure the product has been installed and operated securely and correctly, the fabric can be cleaned with a synthetic or feather duster and can be wiped lightly with a damp cloth.

Maintenance

All our products are manufactured using aluminium and glass reinforced nylon components, they do not present any corrosion problems in normal working environments. If there is a failure of fabric or a component, depending on which, it can be replaced without the need for a new complete blind.

Replaceable components:

Handle ends,
Siderail feet,
Siderails.